

## Schemat podłączenia do instalacji samochodu

# STAG-300 QMAX PLUS

10R - 03 6615  
67R - 01 4289  
110R - 00 4534

"04-123.95.00.2 z dn. 02.08.2017"



AC S.A.  
15-181 Białystok, ul. 42 Pułku Piechoty 50  
tel. +48 85 743 81 00, fax +48 85 653 93 83  
www.ac.com.pl | info@ac.com.pl

**UWAGA !!!**  
Dokładny opis podłączenia do złącza OBD znajduje się w instrukcji podłączenia i programowania sterownika

**UWAGA !!!**  
Odpowiedni bezpiecznik jest dodawany luzem do konfekcji i trzeba go umieścić w gnieździe.

**EMULATOR POZIOMU PALIWA**  
Opis podłączenia znajduje się na schemacie w instrukcji obsługi.

**EMULATOR CIŚNIENIA PALIWA**  
Opis podłączenia znajduje się na schemacie w instrukcji obsługi.

**UWAGA !!!**  
Opis podłączenia sondy znajduje się w pomocy programu diagnostycznego.

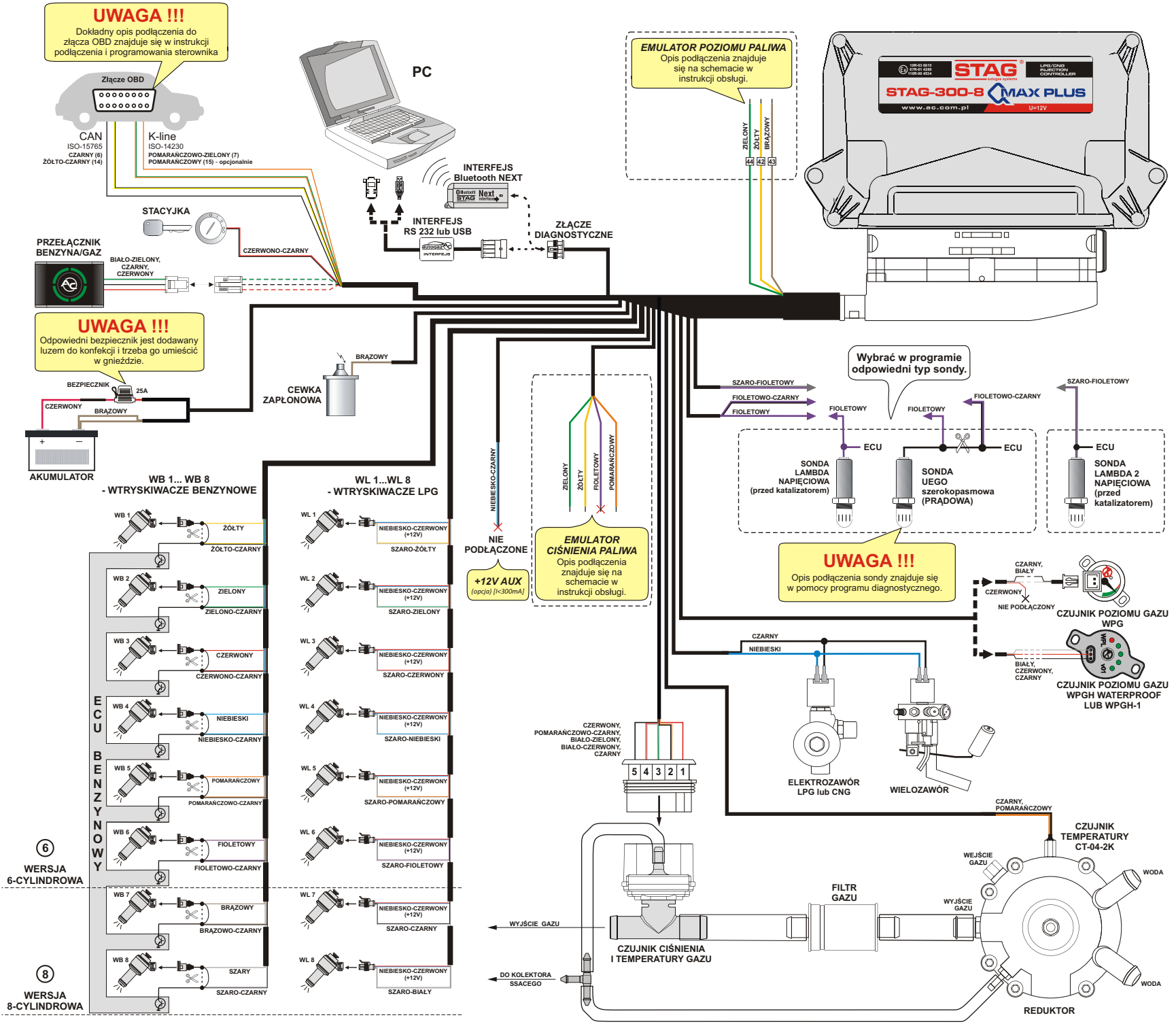

**WERSJA 6-CYLINDROWA**  
**WERSJA 8-CYLINDROWA**



## Wiring Diagram

### STAG-300 QMAX PLUS

10R - 03 6615  
 67R - 01 4289  
 110R - 00 4534

"04-123.95.00.2 z dn. 02.08.2017"



AC S.A.  
 15-181 Białystok, ul. 42 Pułku Piechoty 50  
 tel. +48 85 743 81 00, fax +48 85 653 93 83  
 www.ac.com.pl | info@ac.com.pl

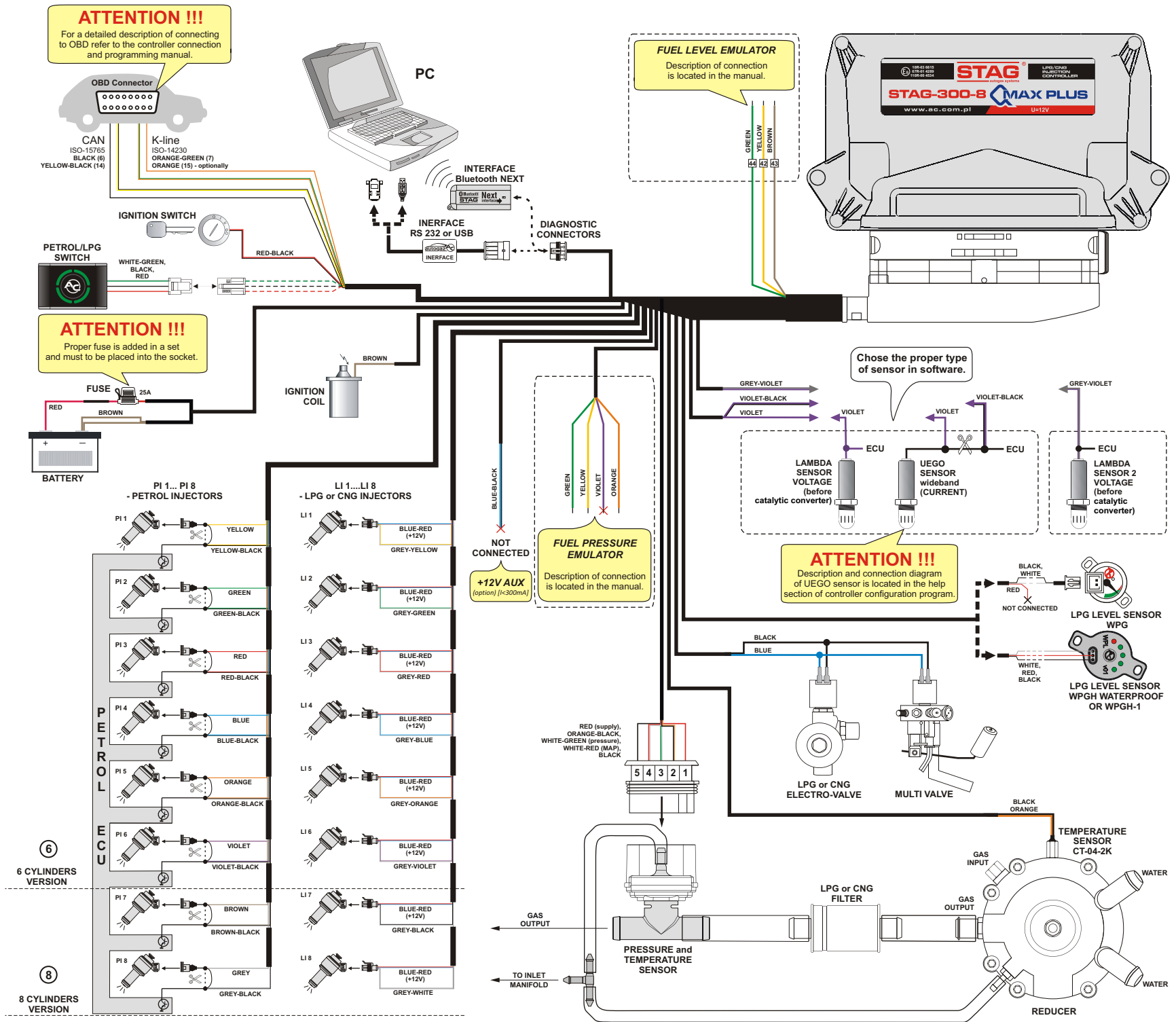

## Схема подключения к автомобильной установке

# STAG-300 QMAX PLUS

10R - 03 6615  
67R - 01 4289  
110R - 00 4534

"04-123.95.00.2 z dn. 02.08.2017"



AC S.A.  
15-181 Białystok, ul. 42 Pułku Piechoty 50  
tel. +48 85 743 81 00, fax +48 85 653 93 83  
www.ac.com.pl | info@ac.com.pl

**ВНИМАНИЕ!!!**  
Подробное описание подключения к соединению OBD представлено в инструкции по подключению и программированию контроллера.

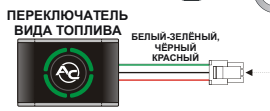
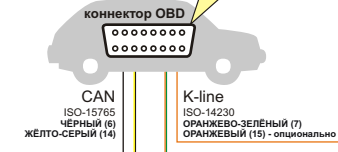

**ВНИМАНИЕ!!!**  
Соответственный предохранитель находится отдельно в составе аксессуаров и следует его поместить в гнездо.

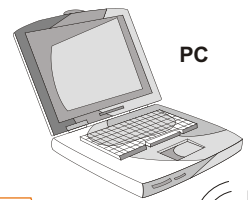
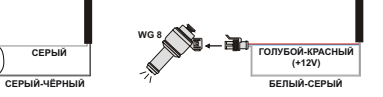
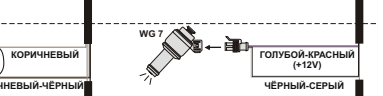
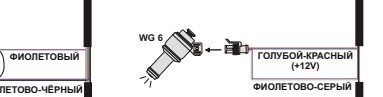
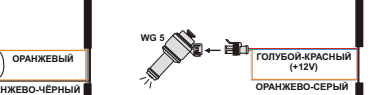
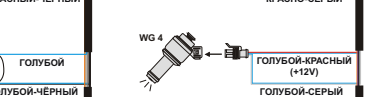
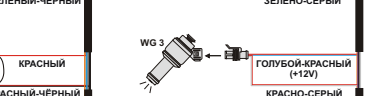
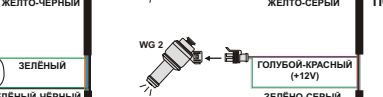
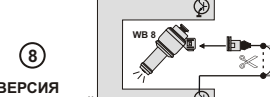
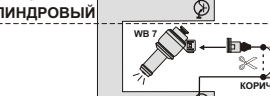
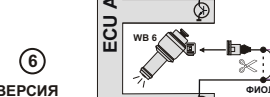
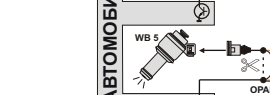
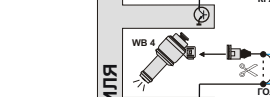
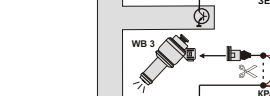
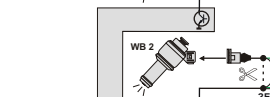
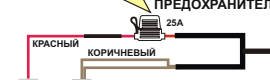

PC



**ЭМУЛЯТОР УРОВНЯ ТОПЛИВА**  
Описание подключения находится на схеме в руководстве пользователя

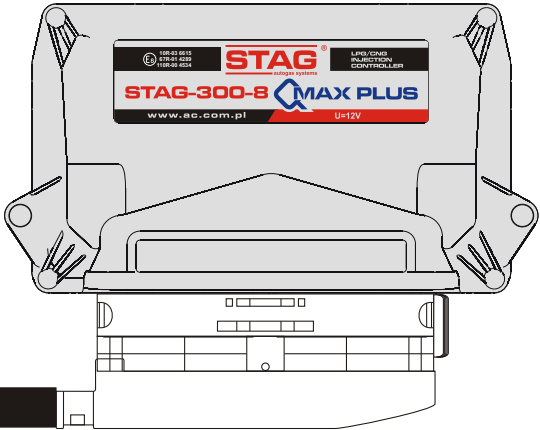
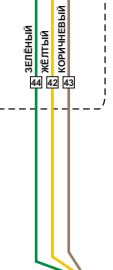

В программе необходимо выбрать соответствующий тип лямбда зонда.

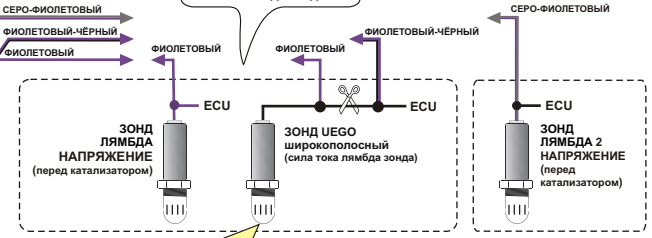

**ВНИМАНИЕ!!!**  
Описание подключения находится в помощи диагностической программы.

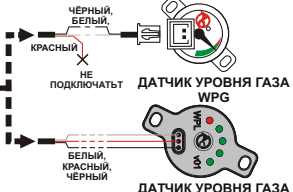

**ЭМУЛЯТОР ДАВЛЕНИЯ ТОПЛИВА**  
Описание подключения находится на схеме в руководстве пользователя

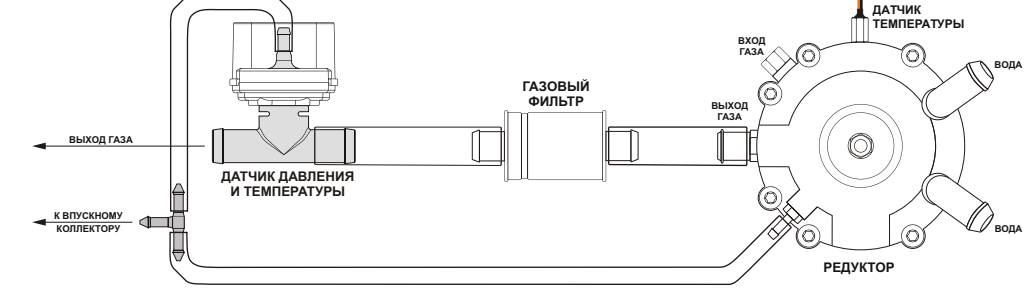
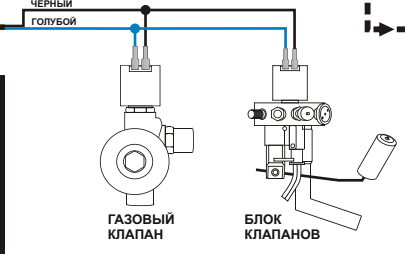
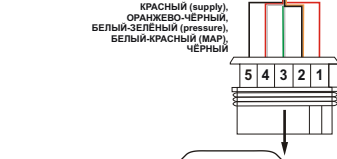

6 ВЕРСИЯ 6-ЦИЛИНДРОВЫЙ

8 ВЕРСИЯ 8-ЦИЛИНДРОВЫЙ

## Esquema de conexión a la Instalación del vehículo.

# STAG-300 QMAX PLUS

10R - 03 6615  
67R - 01 4289  
110R - 00 4534

"04-123.95.00.2 z dn. 02.08.2017"



AC S.A.  
15-181 Białystok, ul. 42 Pułku Piechoty 50  
tel. +48 85 743 81 00, fax +48 85 653 93 83  
www.ac.com.pl | info@ac.com.pl

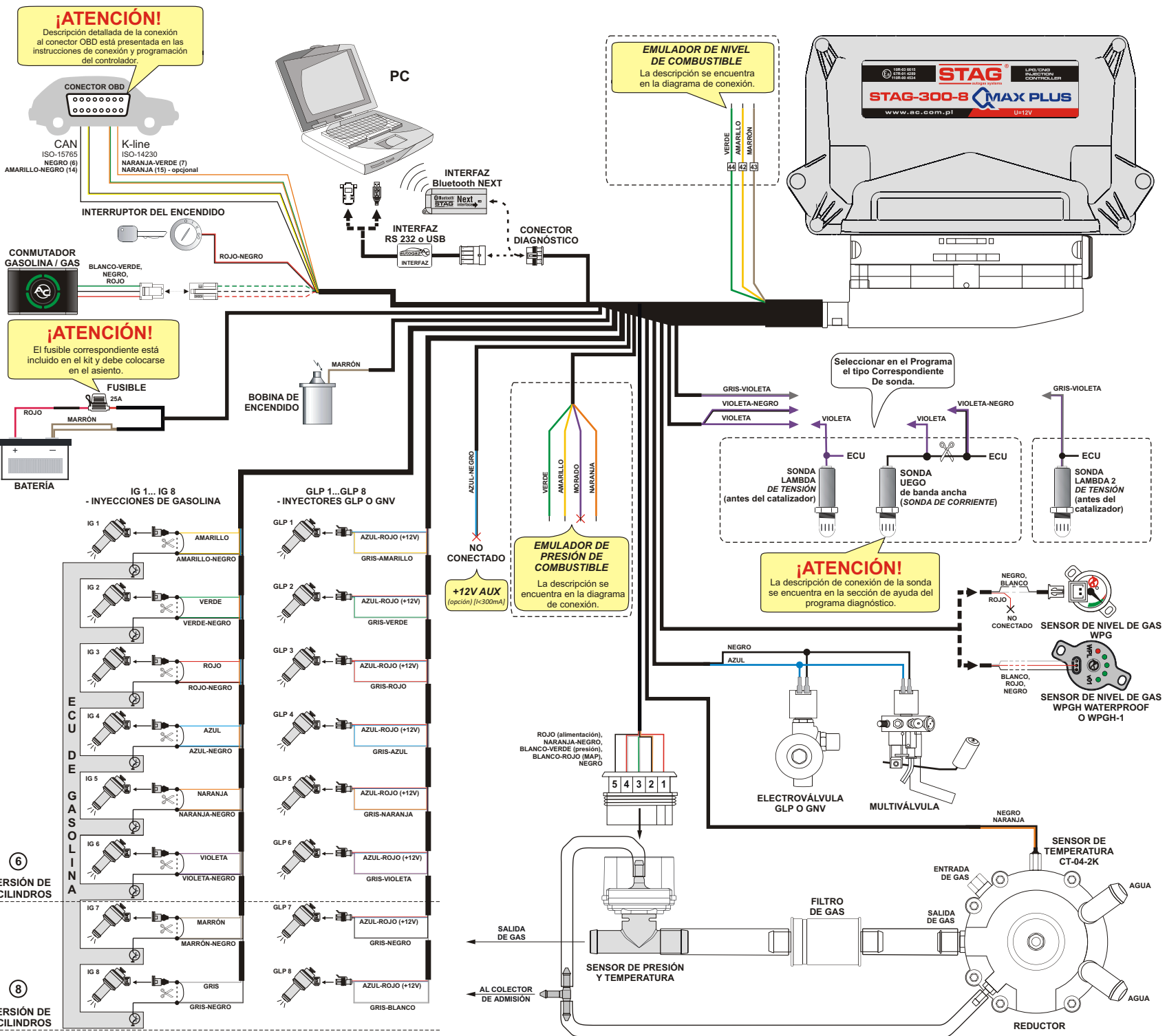

## Schéma pour le raccordement à la voiture

# STAG-300 QMAX PLUS



10R - 03 6615  
67R - 01 4289  
110R - 00 4534

"04-123.95.00.2 z dn. 02.08.2017"



AC S.A.  
15-181 Białystok, ul. 42 Pułku Piechoty 50  
tel. +48 85 743 81 00, fax +48 85 653 93 83  
www.ac.com.pl | info@ac.com.pl

**ATTENTION !!!**  
La description exacte de la connexion au connecteur OBD est située dans la connexion et la programmation de l'utilisateur du contrôleur.

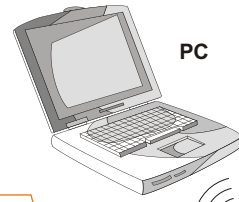
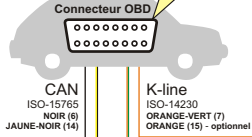

PC

INTERFACE Bluetooth NEXT

INTERFACE RS 232 ou USB

CONNECTEUR DE DIAGNOSTIC

**ÉMULE DE NIVEAU DE CARBURANT**  
Description de la connexion est sur le schéma dans le instruction manuel

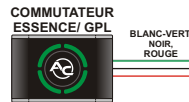
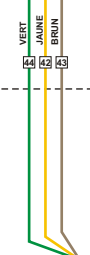

**ATTENTION!!!**  
Le fusible correspondant est ajouté en vrac aux confection et vous devez le mettre dans la douille.

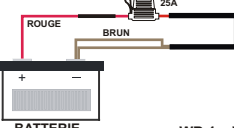

WB 1...WB 8 - LES INJECTEURS ESSENCE

WL 1...WL 8 - LES INJECTEURS GPL

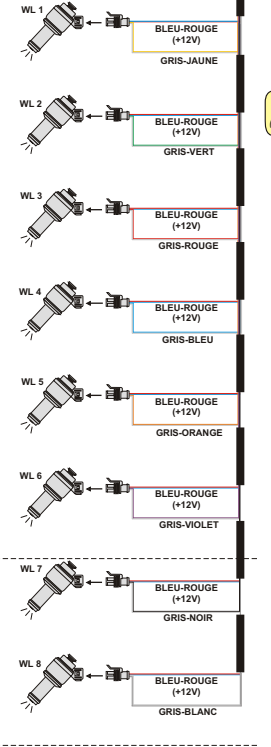
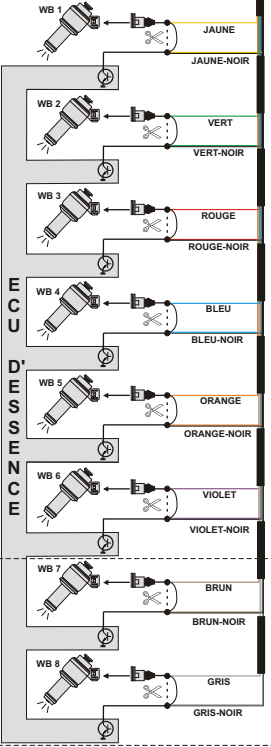

**ÉMULE DE PRESSION CARBURANT**  
Description de la connexion est sur le schéma dans le instruction manuel

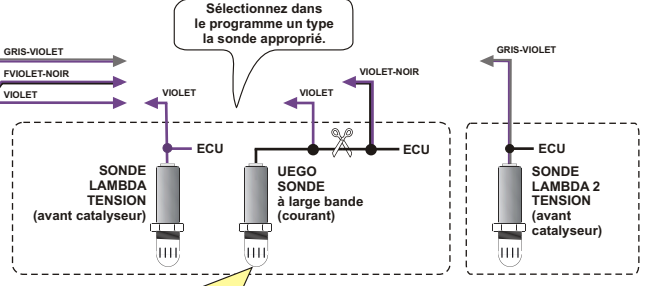

**ATTENTION!!!**  
La description les connexions de la sonde il est à l'appui du programme de diagnostic

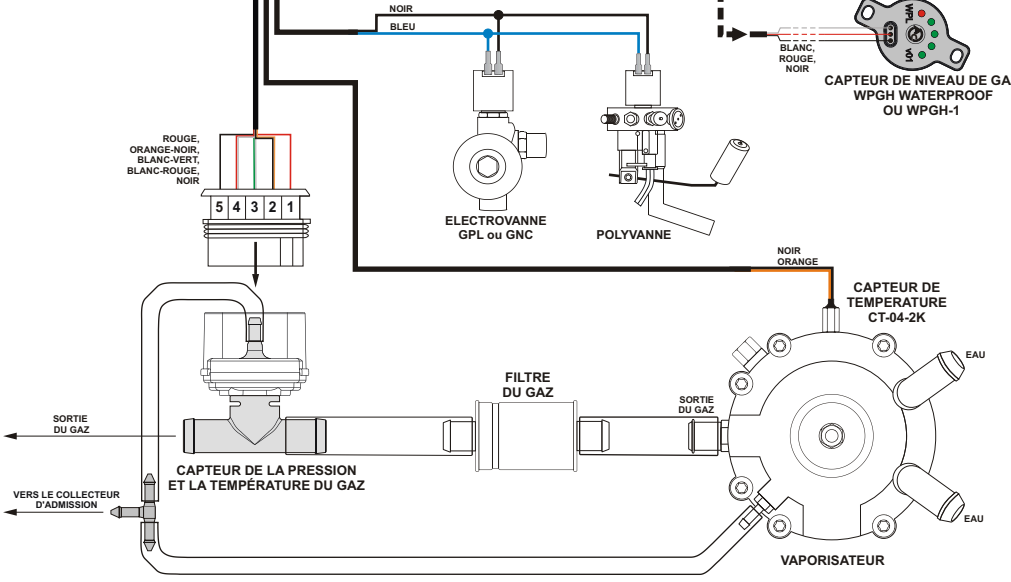
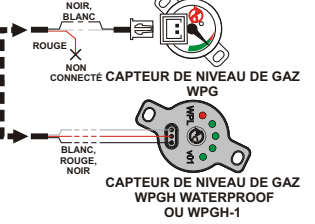

VERSION 6 CYLINDRES

VERSION 8 CYLINDRES





## Schema elettrico

# STAG-300 QMAX PLUS

10R - 03 6615  
 67R - 01 4289  
 110R - 00 4534

"04-123.95.00.2 z dn. 02.08.2017"



AC S.A.  
 15-181 Białystok, ul. 42 Pułku Piechoty 50  
 tel. +48 85 743 81 00, fax +48 85 653 93 83  
 www.ac.com.pl | info@ac.com.pl

**ATTENZIONE !**  
 Per una descrizione dettagliata del collegamento all'OBD fare riferimento al collegamento di controllo e programmazione.

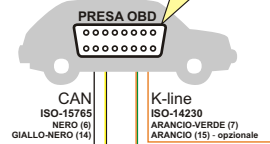

**ATTENZIONE !**  
 Il fusibile corretto si trova all'interno del kit e deve essere inserito nello zoccolo.

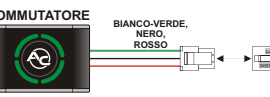

**ATTENZIONE !**  
 Il fusibile corretto si trova all'interno del kit e deve essere inserito nello zoccolo.

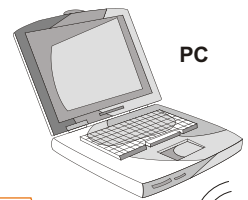
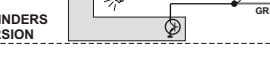
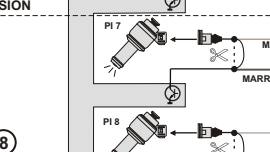
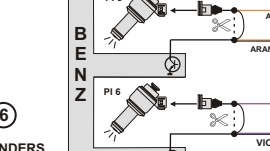
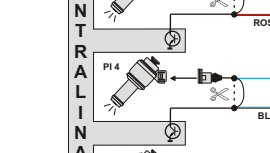
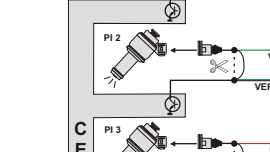
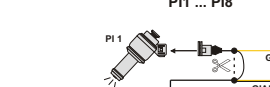
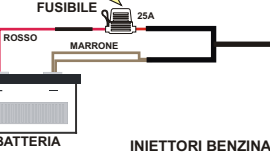

**EMULATORE LIVELLO CARBURANTE**  
 La descrizione dettagliata del collegamento si trova nel manuale.



**EMULATORE PRESSIONE CARBURANTE**  
 La descrizione dettagliata del collegamento si trova nel manuale.

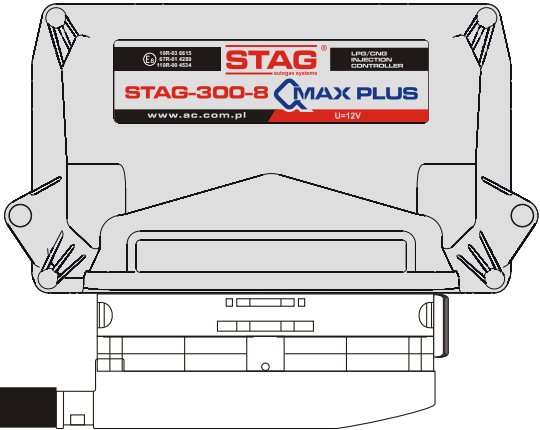

**SCEGLIERE IL TIPO CORRETTO DI SONDA NEL SOFTWARE.**

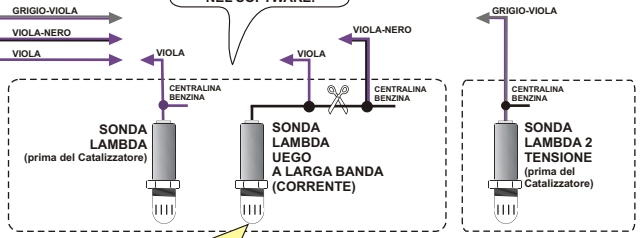

**ATTENZIONE !**  
 Descrizione e schema di collegamento della sonda uego si trovano nella sezione aiuto del programma di configurazione della centralina.

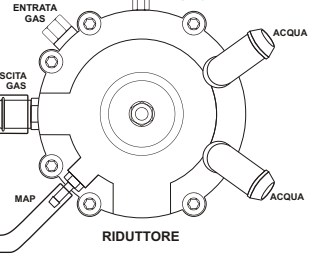
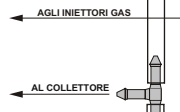
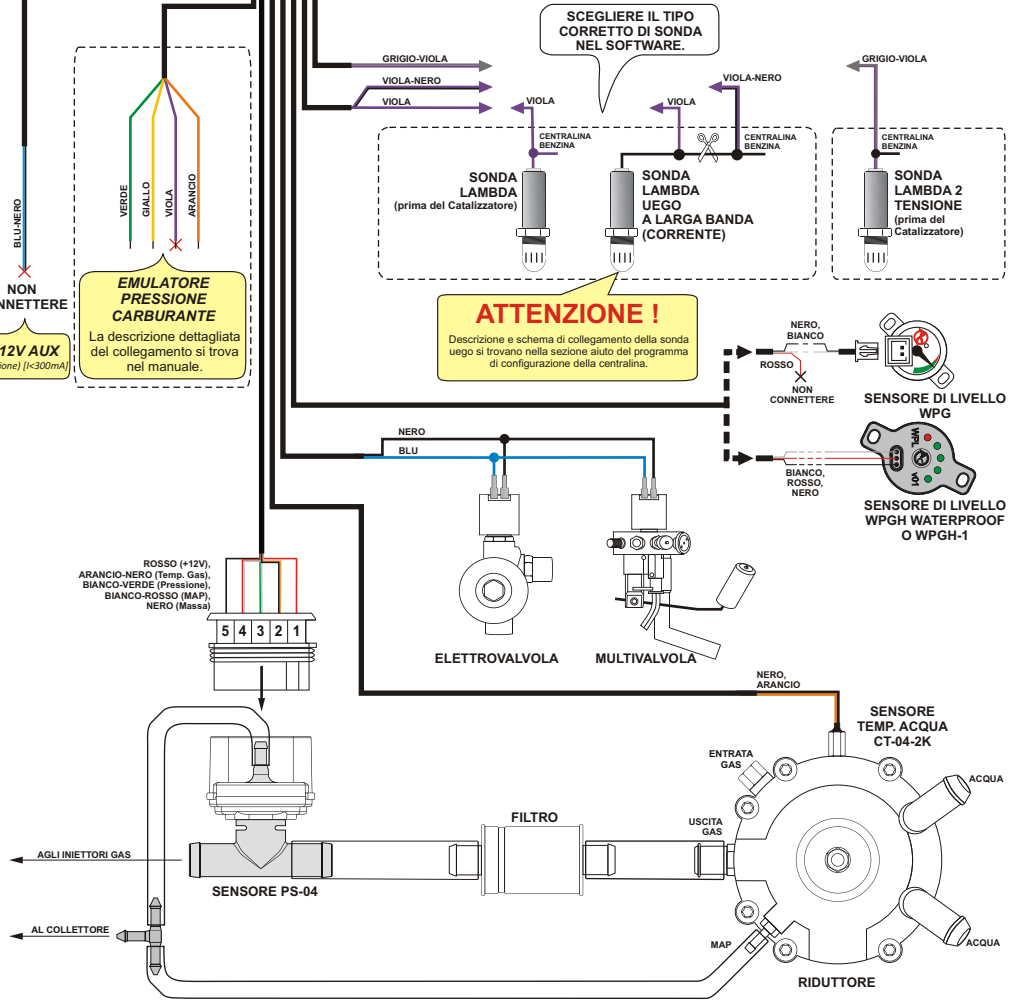
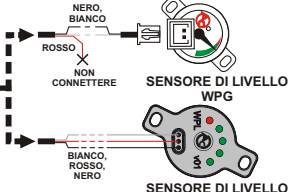

## Diagrama de fiação

# STAG-300 QMAX PLUS



10R - 03 6615  
67R - 01 4289  
110R - 00 4534

"04-123.95.00.2 z dn. 02.08.2017"



AC S.A.  
15-181 Białystok, ul. 42 Pułku Piechoty 50  
tel. +48 85 743 81 00, fax +48 85 653 93 83  
www.ac.com.pl | info@ac.com.pl

**ATENÇÃO!**  
A descrição detalhada da ligação ao conector OBD é incluída no manual de ligação e programação do controlador.

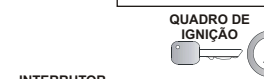
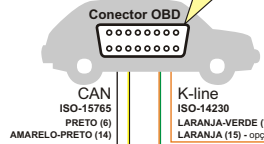

**ATENÇÃO!**  
O fusível apropriado é adicionado em separado e deve ser colocado no soquete.

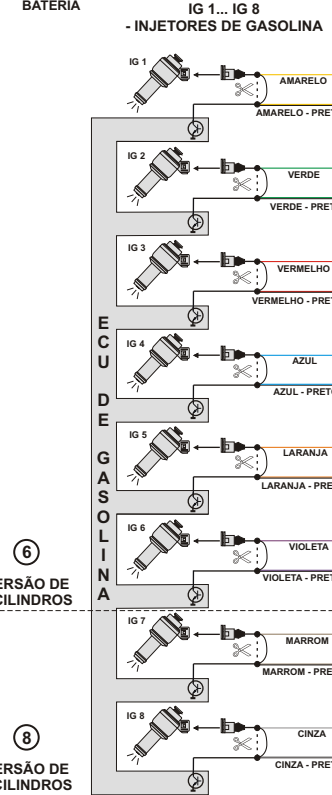
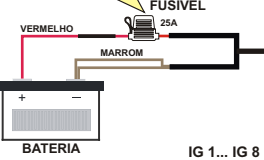

6  
VERSÃO DE 6 CILINDROS

8  
VERSÃO DE 8 CILINDROS

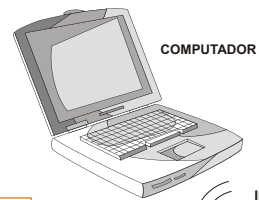

**EMULADOR DE NÍVEL DE COMBUSTÍVEL**  
A descrição da ligação é incluída no esquema, no manual de uso.

**EMULADOR DE PRESSÃO DO COMBUSTÍVEL**  
A descrição da ligação é incluída no esquema, no manual de uso.

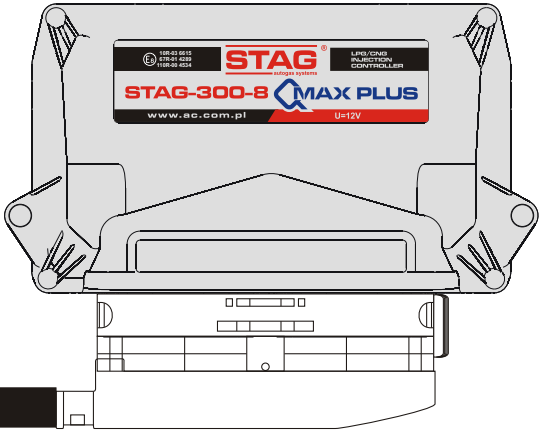

SELECIONE NO PROGRAMA O TIPO APROPRIADO DE Sonda

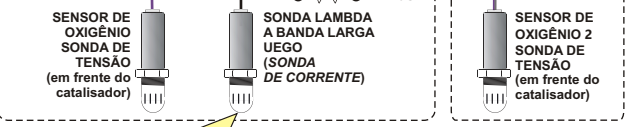

**ATENÇÃO!**  
A descrição da conexão da sonda encontra-se na ajuda do programa de diagnóstico.

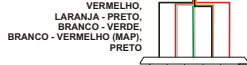
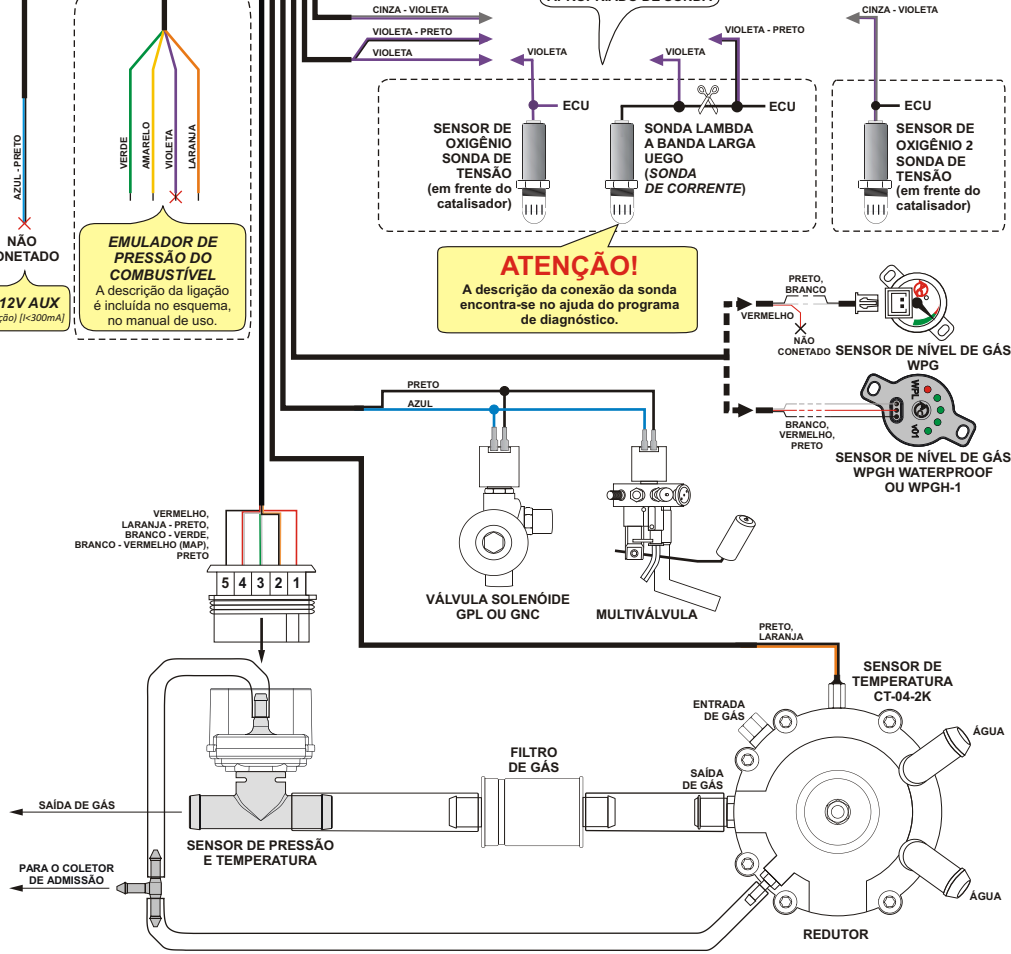
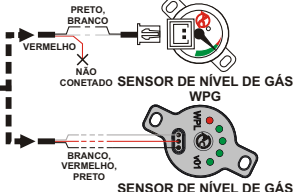

PARA O COLETOR DE ADMISSÃO

REDUTOR